

MAGNETOIMPLOSIVE GENERATORS

A. D. SAKHAROV

Usp. Fiz. Nauk 88, 725-734 (April, 1966)

SEVERAL recent experimental and theoretical papers are devoted to the use of explosions to produce ultra-strong magnetic fields^[1-9]. The same topic was also the subject of a recent international conference (Rome, September 1965). In the USA and in the USSR, fields of 15-25 million gauss were attained in individual experiments. Somewhat weaker fields (2-5 million gauss) can be attained relatively simply. Prospects are being uncovered for investigating electric, optical, and elastic properties of different substances in such hitherto unattainable magnetic fields. In addition, the magnetoimplosive generators can be used to feed pulsed accelerators of charged particles and also for some other purposes (plasma physics research, launching of bodies, etc.).

In this article we describe the physical and structural principles of magnetoimplosive generators and their characteristics, and touch upon problems involving their application.

We use the term "magnetocumulative generators" (MC generators for short), which agrees with Soviet usage, and reflects the basic phenomenon that occurs in these systems, namely the compression (cumulation) of the magnetic flux.

1. PRINCIPLE OF MC

In spring 1952 R. Z. Lyudaev, E. A. Feoktistova, G. A. Tsytkov, and A. A. Chvileva realized the first implosion experiment in the USSR aimed at obtaining superstrong magnetic fields. The experimental setup is shown in Fig. 1 (generators of this type have been designated MK-1). A longitudinal magnetic field is produced inside a hollow metallic cylinder 1 by discharging capacitor bank C through the solenoid wind-

ing 2 (to ensure rapid penetration of the field inside the cylinder, a narrow oblique slot S is cut in the cylinder; subsequently this slot is closed by collapse). An explosive charge (E) is placed outside the cylinder. A converging cylindrical shock wave is excited in this charge (it is set off either by an electric multiple-point initiation system, or by special detonation "lenses"). The instant of initiation is chosen such that the compression of the cylinder begins when the current in the solenoid winding is a maximum.

When the cylinder moves under the influence of the detonation wave with a velocity exceeding 1 km/sec, the entire process of contraction is so rapid, that in first approximation one can neglect the ohmic losses in the cylinder and regard the cylinder as an ideal conductor (for refinements see below). The electric field in an ideal conductor is equal to zero, i.e., the magnetic flux $\Phi = \pi R^2 H$ enclosed in the contracting cylindrical cavity does not change during the contraction. The magnetic field increases in this ideal case in proportion to $1/R^2$, and the energy of the magnetic field, which is equal to $W = (H^2/8\pi) \cdot \pi R^2 l$, where l is the length of the cylinder, increases in the same ratio:

$$\left. \begin{aligned} \Phi &= \pi R^2 H = \text{const}, \\ H &= \frac{H_0 R_0^2}{R^2}, \quad W = \frac{W_0 R_0^2}{R^2}, \\ H \rightarrow \infty \text{ and } W \rightarrow \infty \text{ as } R \rightarrow 0. \end{aligned} \right\} \quad (1)$$

Of course, in a real case the magnetic flux decreases and infinite values of H and W are unattainable. The flux in experiments of this type, is usually lower by a factor 2-3, as was the case in 1952. In addition, at a certain value of R the motion of the cylinder was stopped by the counter pressure of the magnetic field. Nonetheless, even in first experiments a field of 1 million gauss was attained (at an initial field of 30 kG). Measurement of the fields was by means of an induction pickup. A more detailed discussion of systems of the MK-1 type will be presented later; for the present let us consider the operation of magnetocumulative generators from the electrical-engineering point of view.

We can state that the MC generators are based essentially on the same principle used in all other devices in which mechanical energy is converted into electricity. Let us consider a circuit whose inductance L can vary under the influence of external forces. At first we neglect the resistance of the circuit. We have (\sim stands for proportionality)

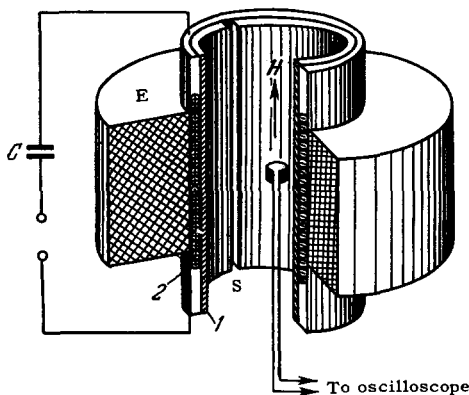

FIG. 1. Diagram of MK-1 generator.

$$\Phi = LI = \text{const}, \quad I \sim \frac{1}{L},$$

$$W = \frac{LI^2}{2} = \frac{\Phi^2}{2L} \approx \frac{L_0 W_0}{L}, \quad (2)$$

i.e., the magnetic field energy W increases with decreasing inductance. In the presence of resistance (R) in the deformed circuit we obtain in lieu of (2)

$$\Phi = \Phi_0 e^{-\int \frac{R}{L} dt}, \quad W = \frac{W_0 L_0}{L} e^{-2 \int \frac{R}{L} dt}. \quad (3)$$

Many various systems were proposed in the USSR and in other countries, besides the systems MK-1, in which the energy and intensity of the magnetic field increases when current-carrying circuits are compressed by implosion products. A typical variant is the MK-2 generator, which we now proceed to describe.

2. MK-2

Figures 2 and 3 show a photograph and the diagram of an MC generator (MK-2) which is of particular interest for the production of strong currents (up to 10^8 A) and very large magnetic-field energies (with up to 20% of the explosive energy converted into magnetic-field energy at relatively high values of the field inten-



FIG. 2. Photograph of the MK-2 generator.

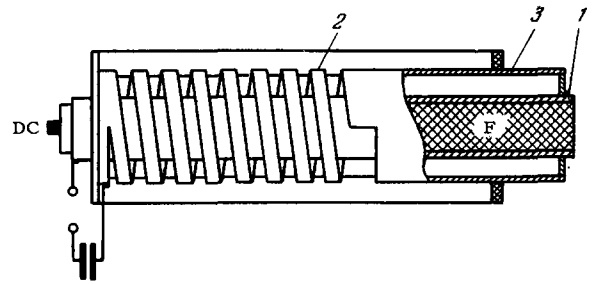

FIG. 3. Diagram of MK-2 generator.

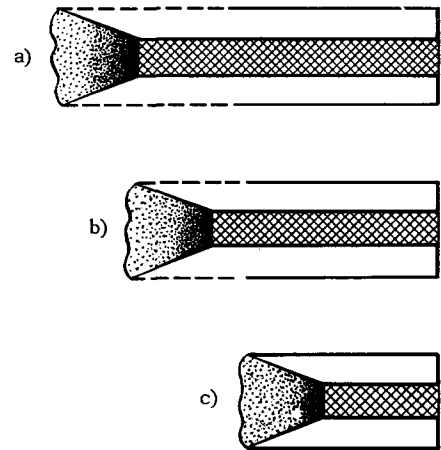

FIG. 4. Stages of operation of the generator MK-2.

sity, up to 2×10^6 Oe). The operating principle of the MK-2 reduces to the following (Figs. 4a-c). When the capsule DC is detonated, the detonation wave propagates through an explosive charge located inside metallic tube 1. The tube stretches, forming at each given instant a cone (Fig. 4a) which short-circuits first the helix 2 and then the solid shell 3 in such a way, that the inductance of the circuit, made up of the helix 2, tube 1, and the coaxial section 3 decreases continuously as the detonation wave propagates to the right. The expanding tube compresses at the same time the magnetic field, increasing its energy. During the last stage of operation of the MC generator (Fig. 4c), the helix is completely disconnected and the magnetic field, which coincides in this case with the DC field, is now compressed in the decreasing volume between the external and internal walls of the coaxial.

Practical realization of MK-2 systems with high output characteristics has called for extensive research on the part of a large staff, concluded essentially in 1956 (the first MK-2 generator was constructed in 1952, and in 1953 currents up to 100 million A were obtained). During the course of these investigations, the following problems were solved:

1) Prevention of cracks in the expanding tube, high symmetry of expansion, choice of the material (copper was used in all but the largest systems), choice of dimensions and tolerances, assurance of homogeneity of

the explosives, etc. The results were monitored during this stage with the aid of pulsed x-ray photography and other methods.

2) Minimization of magnetic flux losses in the helical section—use of helices with variable pitch and with continuous transition to the coaxial section, beveling the edges of the helix turns at the flare angle of the tube, etc.

3) Design and experimental development of the coaxial section (arbitrarily called the “beaker”), in which the main growth of the magnetic field energy takes place.

4) Development of systems for transformer coupling the electric energy from the coaxial section (Fig. 5).

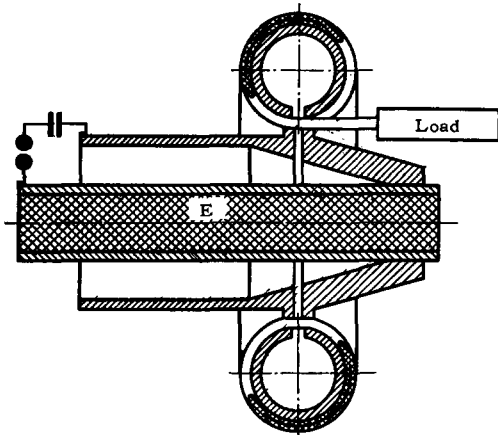

FIG. 5. MC transformer system.

This makes it possible to connect the MK-2 generator to loads with much larger inductances.

5) Development of systems in which the initial magnetic flux is produced with the aid of permanent magnets.

6) Development of cascade systems coupled by transformers.

The MK-2 generators were developed in the USSR in a large assortment of sizes and power ratings. With the generator weighing 150 kg (the weight of the explosive in the “beaker” is 15 kg), more than 10^7 J goes over into magnetic-field energy. A capacitor bank with the same discharge energy would be a very complicated and expensive structure.

3. THEORY OF MK-1 AND PRODUCTION OF ULTRA-STRONG FIELDS

The simplest from the theoretical point of view is the MK-1 system. In addition, this is precisely the system yielding the strongest magnetic fields (up to 25 million Oe). Let us consider, using MK-1 as an example, some principal features of the operation of MC generators, and let us make allowance first for the finite conductivity of the cylinder that compresses the magnetic flux. Actually the conductivity of a metal de-

pends on its density and temperature, which vary during the course of the contraction. If this dependence, as well as the equation of state of the cylinder material, is assumed known, then simultaneous solution of the system of partial differential equations describing one-dimensional radial contraction and the flow of induced eddy currents in the moving metal can be solved by numerical methods (the numerical solution of partial differential equations involves reducing them to difference equations and can be carried out in practice only with high-speed computers). Of course, no analytic solution can be obtained for the general case. However, the role of the finite conductivity of the cylinder material can be explained qualitatively with the aid of the approximate skin-layer method known from electrical engineering. In this method the exact distribution of the current in the cylinder is approximated by an “exponential profile” (4). The current density is

$$j(r) = j_0(t) e^{-\frac{x}{\delta(t)}}. \quad (4)$$

Here $\delta(t)$ is the depth of the skin layer and $x = -R(t)$, where $R(t)$ is the radius of the cylindrical cavity; this function is assumed known. The relation (4) is exact if H increases on the boundary exponentially: $H \sim \exp(\lambda t)$, where λ is a constant. In this case δ is constant and is equal to

$$\delta = \sqrt{\frac{1}{4\pi \cdot 10^{-9} \sigma \lambda}}; \quad (5)$$

σ is the conductivity in $\text{ohm}^{-1} \text{cm}^{-1}$, δ is in cm, and λ in sec^{-1} . In the skin-layer method, formulas (4)–(5) are used for arbitrary law of increase of $H(t)$, with the quantity λ in (5) assumed equal to $(1/H)(dH/dt)$. Regarding the change in the flux as a correction, we get $\lambda = -2(1/R)(dR/dt)$. In addition, it is obvious that $H = 0.4\pi j_0 \delta$, and the electric field, in a system, moving together with the metal, $E = (10^{-8}/2\pi R)(d\Phi/dt) = j_0/\sigma$. Combining all these formulas we get

$$\frac{1}{\Phi} \frac{d\Phi}{dt} = \frac{\alpha}{R} \frac{dR}{dt}, \quad (6)$$

where the “loss coefficient” α is equal to (putting $v = |dR/dt|$)

$$\alpha = \frac{10^4}{(0.2\pi)^{1/2} \sigma^{1/2} R^{1/2} v^{1/2}}. \quad (7)$$

An estimate for copper ($\sigma = 6 \times 10^5 \text{ ohm}^{-1} \text{cm}^{-1}$) at $v = 10^5 \text{ cm/sec}$ and $R = 1 \text{ cm}$ leads to $\alpha = 0.05$, i.e., to good conservation of the flux. This simple estimate shows that our assumption, namely that in MC systems the magnetic flux is approximately conserved, is valid. We note incidentally that in the particular case when $\sigma = \text{const}$ and $v \sim 1/R$, an analytic (self-similar) solution of the partial differential equation corresponding to a constant coefficient α , with $\Phi \sim R \sim t^{\alpha/2}$, has been obtained (M. P. Shumaev and the author, 1952).

Under real conditions the conductivity decreases strongly because of the Joule heating of the metal (all

metals have a negative temperature coefficient of conductivity). A particularly important role is played by the "surface implosion" of the metal layer in which heat exceeding the sublimation energy is released. An expanding metal loses its metallic conductivity. If these processes result in production of a zone of reduced conductivity, comparable in magnitude with the radius of the cavity and having such a conductivity that the thickness of the skin layer in it is also comparable with the radius, then appreciable losses of the magnetic field occur. However, if the pressure of the magnetic field $H^2/8\pi$ and the density of the released Joule heat, which is comparable with it, are smaller than ρv^2 , where ρ is the density of the shell, then the rate of the thermal expansion of the evaporated layer is smaller than $v = |dR/dt|$. The role of the surface implosion processes will then not be catastrophic even for an unfavorable conductivity of the plasma layer. The criterion

$$\rho v^2 > \frac{H^2}{8\pi} \quad (8)$$

comes into play also when we consider problems involving the stopping of the shell by the magnetic counterpressure, with allowance for the compressibility of the shell. At sufficiently large shell velocities, it is possible to attain arbitrarily high magnetic-field energies. In the Soviet experiments the velocity of the cylindrical shells was 10–20 km/sec.

A question of practical importance is how to ensure very good cylindrical symmetry of compression of the metallic cylinder, i.e., high quality of the cylindrical charge, and of the detonation lenses, and precise simultaneity of initiation of the electric detonators. Slow residual deviations from symmetry increase upon compression, because of the dynamic instability of cylindrical-shell focusing. Therefore in practice the change in radius is limited to not more than a factor of 10. To obtain record fields it is therefore necessary to have very large initial fields. In Soviet experiments the MK-2 system was used to produce the initial fields (Fig. 6). Figure 7 shows an oscillogram obtained with

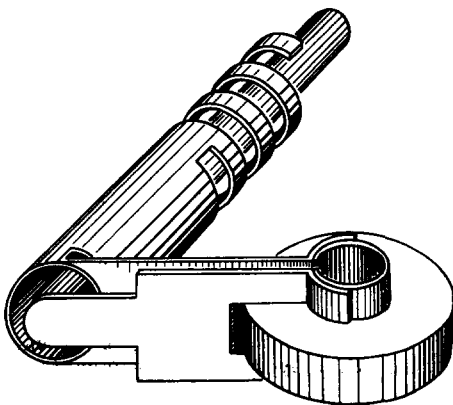

FIG. 6. Use of MK-2 generator to feed the core of MK-1 generator.

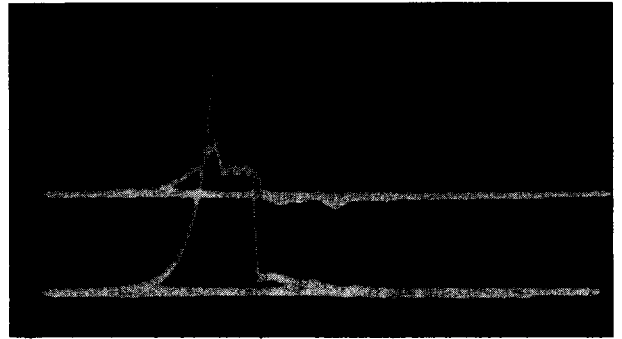

FIG. 7. Oscillogram showing the magnetic field intensity. Beam 1—background (signal from shorted wires); beam 2—signal from measuring turn (integration with RC network).

a calibrated inductive pickup in an experiment in which a field of 25 million gauss was registered.

4. APPLICATIONS OF MC

Measurements of the properties of substances in ultrastrong magnetic fields, obtained with the aid of MC, are made difficult by the short duration of the process, by the presence of an air shock wave and of cumulative jets and particles in many cases, and by mechanical, thermal, and electric noise produced by the variable magnetic field itself. Special shielding of the measuring devices is necessary, and a pulse measurement technique must be used. In many cases it is advantageous to take the ultrastrong current outside the noise zone (Fig. 8, taken from [3], shows one of the devices of this type). Therefore the results

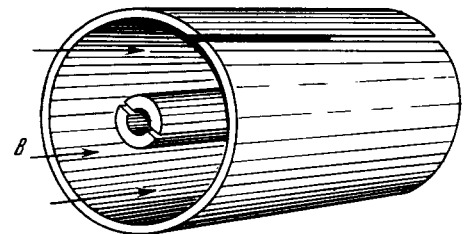

FIG. 8. Magnetic-field concentrator.

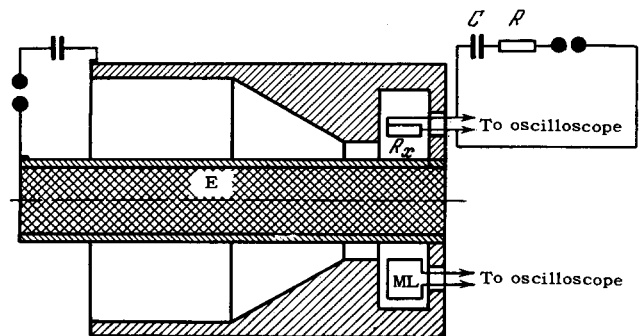

FIG. 9. Diagram of experiment on the measurement of the resistance of graphite. R_x —sample, ML—loop for measuring H; $RC \gg$ rise time of H.

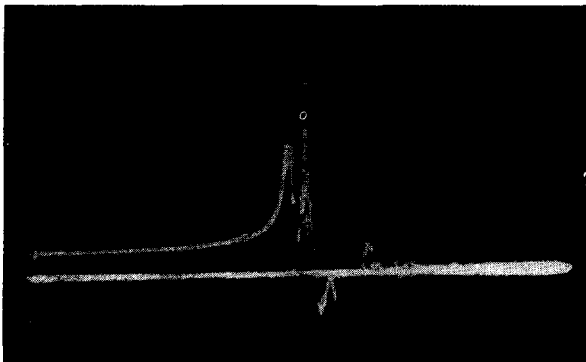

FIG. 10. Oscillogram of voltage on graphite sample.

actually obtained to date are still not too numerous. Figure 9 shows one of the experimental setups for the measurement of the resistance of graphite in magnetic fields up to 1.5×10^6 Oe, obtained in a coaxial MC system, and Fig. 10 shows a characteristic oscillogram of the voltage on the sample (the increase in the voltage is due to the increase of the resistance of the sample and to the increase of the magnetic field intensity). Experiments were made aimed at observing the rotation of the light polarization plane in a magnetic field (Faraday effect)^[2,3]. The very large change of light intensity observed in the experiments offers evidence that the plane of polarization was rotated by many thousands of degrees. American and Italian researchers have confirmed the linear character of the Faraday effect in glass in megagauss magnetic fields. The Americans obtained photographs of spectra of the Zeeman effect in fields up to 2 million gauss. The shift of the center of the Zeeman multiplet, resulting from compression of atoms by pressure of the magnetic field, was registered (the magnetic field is somewhat smaller inside the atom because of the atomic diamagnetism).

Soviet and American researchers have paid much attention to the use of MC systems for launching metallic bodies at escape velocities. This is of interest both for simulation of micrometeors and for experiments on physical processes at ultrahigh pressures, obtained when such bodies strike partitions. Figure 11 shows the diagram of a setup for launching an aluminum ring (weight ~ 2 g), which is accelerated by a pressure of a magnetic field in an annular gap to velocities exceeding 100 km/sec (this, to be sure, vaporizes the ring).

The most fundamental scientific application of MC generators, in our opinion, may be the supply of very high power to elementary-particle accelerators, and to measurement and recording apparatus. Let us consider a cyclic inductive accelerator constructed without an iron core (although this may not be the optimal design). The momentum of the accelerated proton is $p \sim HR$. The energy of the magnetic field is

$$W \sim R^3 H^2 \sim \frac{P^3}{H}$$

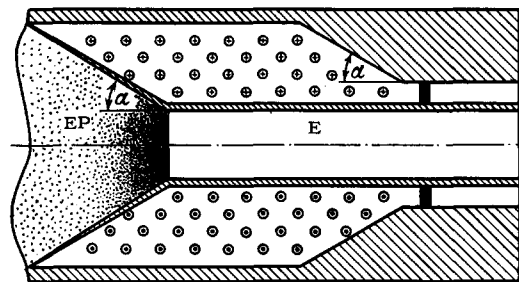

FIG. 11. Diagram of setup for launching a ring.

The proportionality coefficient can be determined by using as an example the already constructed coreless pulsed betatrons (see, for example, I. A. Pavlovskii et al.^{[10]*}). We obtain (the energy of the magnetic field is expressed in tons of TNT equivalent, 1 ton = 4×10^9 J)

$$W \text{ (tons)} = \left(\frac{10^7 \text{ (G)}}{H} \right) \left(\frac{P}{10^{10} \text{ (eV/c)}} \right)^3. \quad (9)$$

We see that in order to attain an energy of 1,000 GeV = 10^{12} eV, which is the dream of modern high-energy physics, using $H = 10^7$ G at the center of the betatron, which certainly is not a limit, the required magnetic energy should be the equivalent of about 1 million tons of TNT. Obviously, the total energy should be several times larger, i.e., we are dealing with an underground explosion of a thermonuclear charge of "average" power. Such an explosion can be carried out without the spread of radioactive products at a depth somewhat greater than 1 km. The main expense is the construction, at such a depth, of a chamber with a volume larger than $10,000 \text{ m}^3$, and the erection of several thousand tons of metal structures in such a chamber. We can count, however, on obtaining 10^{18} protons within a time of the order of 10^{-5} sec (the coefficient of utilization of the explosion energy is approximately $10^{-3}\%$). At such intensities we can obtain much scientific information in a single experiment. The repetition of the experiment 50–100 times will be comparable in cost with the creation of a continuously operating 1,000-GeV accelerator (several billion rubles). Of course, it will be necessary to develop special recording apparatus, for example a system of photomultipliers registering the synchrotron radiation of the products of collision between the accelerated protons and the target, occurring in special "measuring" magnetic fields in a large volume. From the radius of deflection in the magnetic field it is possible to determine in this case the momentum of the secondary particles, whose mass can be calculated from the spectrum and the intensity of the synchrotron radiation.

We must point also to another almost fantastic possibility. The use of large pulsed magnetic lenses (with

*At an energy 5×10^5 J and a maximum field 1.2×10^5 Oe, the attained electron energy is 100 MeV.

magnetic-field energy of hundreds of kilotons) makes it possible to focus a beam with an intensity $10^{18}/10^{-5} = 10^{23}$ protons/sec on an area of 1 mm^2 . In this case it is possible to reliably register processes with colliding beams from two accelerators with cross section of the order of 10^{-30} cm^2 . To perform such experiments we must, of course, have automatic (feedback) systems to compensate for space charge and correct the magnetic field. Regardless of the supergrandiose projects just described, it seems to us that MC generators can be useful in many fields of scientific research.

¹C. M. Fowler, W. B. Garn, and R. S. Caird, *J. Appl. Phys.* **31**, 588 (1960).

²R. S. Caird, W. B. Garn, D. B. Thomson, and C. M. Fowler, *J. Appl. Phys.* **35**, 781 (1964).

³F. Herlach and H. Knoepfel, *Rev. Sci. Instrum.* **36**(8), 1088 (1965).

⁴A. D. Sakharov, R. Z. Lyudaev, E. N. Smirnov, Yu. N. Plyushchev, A. I. Pavlovskii, V. K. Chernyshev, E. A. Feoktistova, E. I. Zharinov, and Yu. A. Zysin, *DAN SSSR* **165**, 65 (1965), *Soviet Phys. Doklady* **10**, 1045 (1966).

⁵Ya. P. Terletskiĭ, *JETP* **32**, 387 (1957), *Soviet Phys. JETP* **5**, 301 (1957).

⁶E. I. Bichenkov, *PMTF* **6**, 3 (1964).

⁷J. D. Lewin and P. F. Smith, *Rev. Sci. Instrum.* **35**, 541 (1964).

⁸G. Lehner, J. G. Linhart, and J. P. Somon, *Nucl. Fusion*, No. 4, 362 (1964).

⁹F. Bitter, *Scientific American* **213**(1), 65 (1965).

¹⁰A. I. Pavlovskii, G. D. Kuleshov, G. V. Sklizkov, Yu. A. Zysin, and A. I. Gerasimov, *DAN SSSR* **160**, 68 (1965), *Soviet Phys. Doklady* **10**, 30 (1965).

Translated by J. G. Adashko